

# MC2X8

WLAN + 5G/LTE Client Adapter

## Manual



MC2X8-A (Wifi6)



MC2X8-E (Wifi6 + 5G/LTE)



MC2X8-R (Wifi6 + RedCap 5G/LTE)

# Inhaltsverzeichnis

<b>1 Technical description MC2X8</b>	<b>3</b>
1.1 Antenna Connectors and LED's at MC2X8-A	4
1.2 Antenna Connectors and LED's at MC2X8-E	4
1.3 Antenna Connectors and LED's at MC2X8-R	5
1.4 Front panel LEDs	6
1.5 Connections on the MC2X8	8
1.5.1 MC2X8 with M12 connection	8
1.5.2 MC2X8 with WK8 connection	8
1.6 Technical properties	9
1.7 WLAN interface	9
1.8 LTE-5G interface	9
1.8.1 MC2X8-E	9
1.8.2 MC2X8-R	10
1.9 Safety and installation instructions	11
<b>2 Initial start-up</b>	<b>12</b>
2.1 Initial start-up of the MC2X8	12
2.1.1 Initial start-up with the MC-Config-Program	12
2.1.2 Initial start-up via the MC WEB interface	13
2.1.3 Startup via the MC WEB-Interface	13
2.2 Resetting the settings to default values	13
2.3 Default-Konfiguration	14
2.4 Quick guide to configure the MCX8	14
2.4.1 Establish a WLAN connection:	14
2.5 Configuring the MC2X8	16
<b>3 5G / LTE settings</b>	<b>16</b>
3.1 Unlocking the SIM card by entering the PUK	17
<b>4 Open Source Compliance Information</b>	<b>18</b>

# Abbildungsverzeichnis

Figure 1: Overall system (example)	3
Figure 2: Front panel of the MC2X8-A	4
Figure 3: MC2X8-E front panel	4
Figure 4: MC2X8-R front panel	5
Figure 5: Connections on the rear of the MC2X8-M12	8
Figure 6: Setting for the initial configure of the MC MCX8	12
Figure 7: Initial setup with the MCCconfig program	12

# 1 Technical description MC2X8

The MC2X8 is available in 2 variants.

- 1) MC2X8-A with 802.11ax (Wifi 6) interface
- 2) MC2X8-E with 802.11ax (Wifi 6) Interface and LTE/5G modem (CAT 5)
- 3) MC2X8-R with 802.11ax (Wifi 6) Interface and LTE/5G RedCap modem (CAT 5)

The MC2X8 can be used to connect network devices wireless and wired to each other and to the Internet in various scenarios.

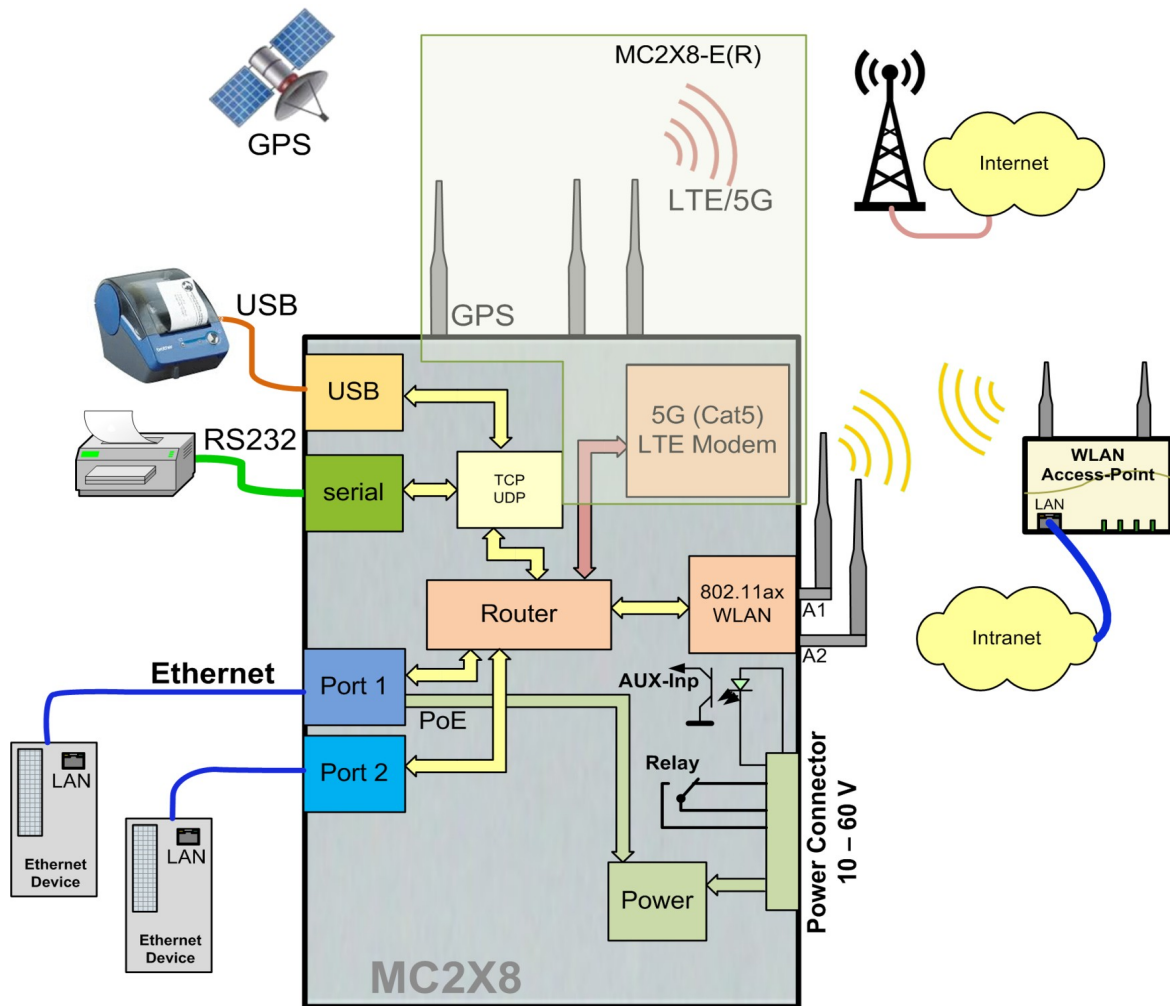

Figure 1: Overall system (example)

## 1.1 Antenna Connectors and LED's at MC2X8-A

The following figure shows how the indicator LEDs and connections are arranged on the MC2X8-A.

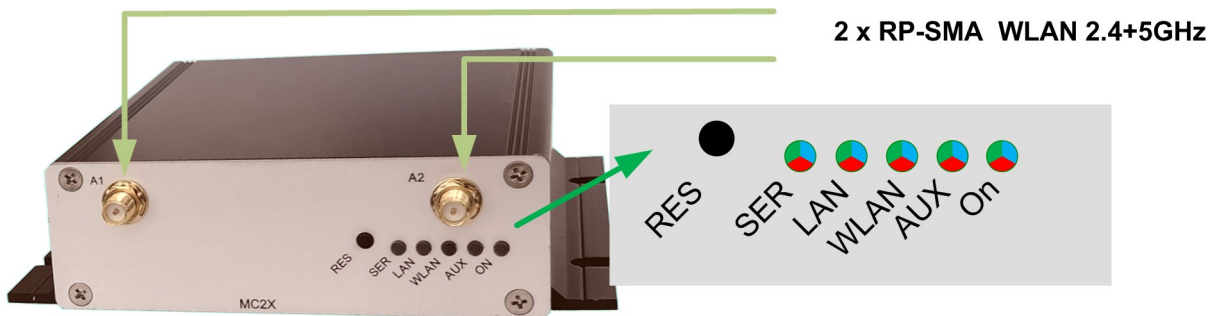

Figure 2: Front panel of the MC2X8-A

## 1.2 Antenna Connectors and LED's at MC2X8-E

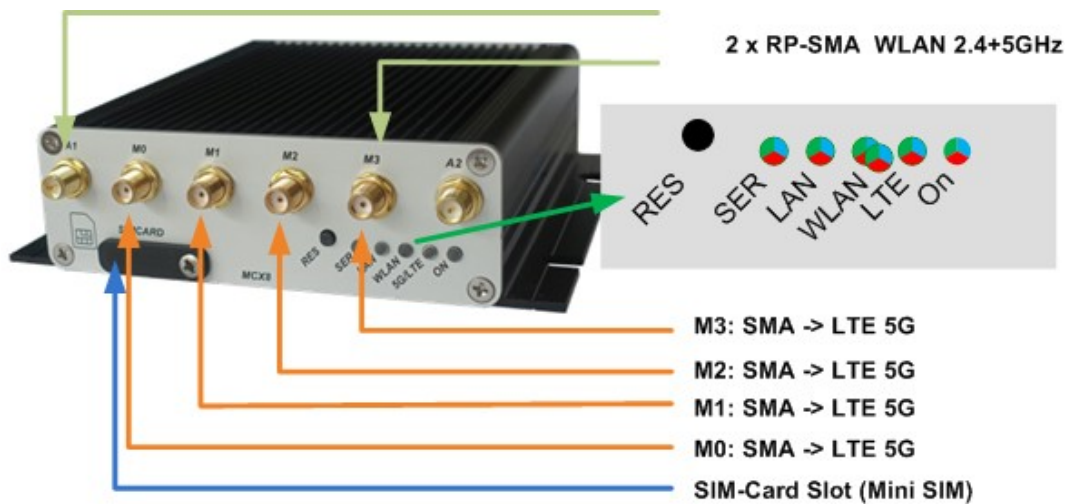

Figure 3: MC2X8-E front panel

Properties of the LTE-5G antenna connections when using a Quectel RM520Q-GL 5G card::

Connection	Description	Frequency range	Impedance
M0	- 5G NR (n41/n77/n78/n79 TRX1); - LTE LMHB TRx0; - B42/B43/B48 MIMO1	600–5000 MHz	50 Ohm
M1	- 5G NR (n77/n78/n79 DRx, n41 TRX0) - LTE MHB MIMO1; - B42/B43/B48 DRX - LAA PRX	1100–6000 MHz	50 Ohm
M2	- 5G NR (n77/n78/n79 MIMO2,n41 DRX); - LTE MHB MIMO2; - B42/B43/B48 MIMO2 - LAA DRX - <b>GNSS L1 (GPS)</b>	1400–6000 MHz	50 Ohm
M3	- 5G NR (n77/n78/n79 TRx0, n41 MIMO2); - LTE LMHB DRX; - B42/B43/B48 TRX0	600–5000 MHz	50 Ohm

Table 1: LTE-5G Antenna connections

### 1.3 Antenna Connectors and LED's at MC2X8-R

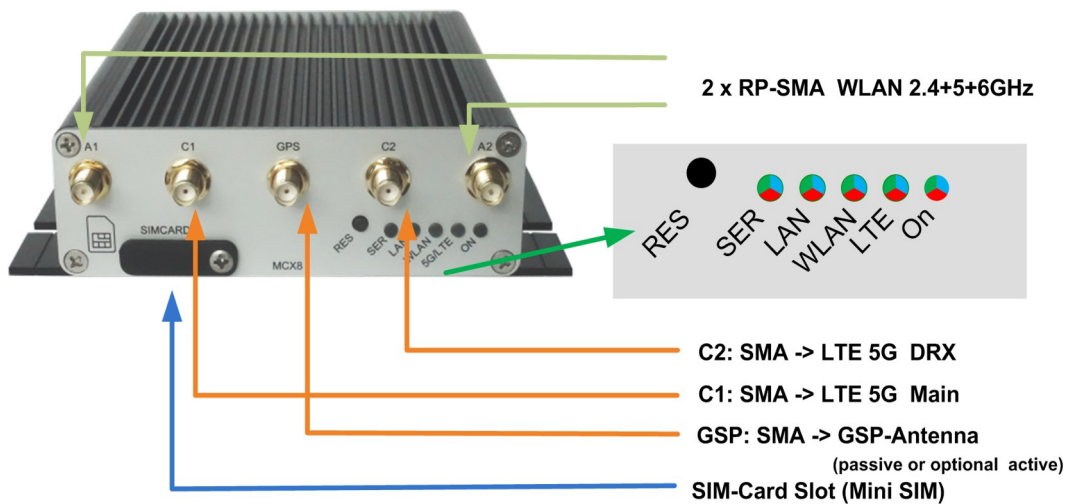

Figure 4: MC2X8-R front panel

Properties of the LTE-5G antenna connections when using a Quectel RG255C-GL card:

Connection	Description	Frequency range
C1 ANT_MAIN	5G NR: LB/MHB/UHB TRX LTE: LB/MHB/UHB TRX	LB: 617–960 MHz MHB: 1695–2690 MHz UHB: 3300–5000 MHz
C2 ANT_DRX	5G NR: LB/MHB/UHB DRX LTE: LB/MHB/UHB DRX	
GPS ANT_GNSS	- <b>GNSS L1 &amp; L5</b>	1400–6000 MHz

Table 2: MC2X8-R GPS LTE/5G Antennenanschlüsse

## 1.4 Front panel LEDs

The 5 LEDs on the front indicate the operating status of the MC2X8. All LEDs are 3-color red, green and blue LEDs. If all three colors are switched on, the LEDs light up white.

All 5 LEDs light up white once briefly after switching on or after a reset. If the WLAN + LAN + SER LEDs flash blue, either a new firmware is being flashed or a new configuration is being activated.

LED	Condition	Function
On	off	No or insufficient supply voltage
	green	Supply voltage connected
	Green / orange flashing	<b>Normal operation</b> This green <--> orange flashing indicates that the MC2X8 is working.
	Blue / orange flashing	(from firmware 3.15) Indicates that the MC is not active as a bridge due to insufficiently secure settings. The configuration interfaces (WEB + MCConfig) are active. Follow the instructions in the web interface or in the MCConfig programme. (Config→Security) On delivery or after a default reset, this status is displayed because no user/password is set.
AUX	MCX8-A	No function has yet been assigned to this LED
LTE	MCX8-E(R)	
	off	LTE is not activated
	Blue / off flashing	MC waits for the detection and the first reaction of the LTE card.
	White / off flashing	The MC performs an initial initialization of the LTE card
	Green / off flashing (1:1)	Provider search + registration at the base station
	Green / off flashing (1:3)	Login OK. Data dial-in (User+Password+APN) is performed
	Green / Blue (quick change)	PIN is transferred
	Green / Blue flashing permanently	PIN incorrect
	White/red alternation	PIN attempts are exhausted. The PUK is requested on the configuration website.
	Red/green/blue change	No SIM was recognized in the slot.
	Green permanent	Internet connection is established
		The status of the LTE connection is indicated by a series of short red flashes every 10 seconds: 1 x red → 2G 2 x red → 3G 3 x red → 3.5G 4 x red → 4G (LTE)
	Green / light blue flashing	Base station supports 5G : NSA (None Stand Alone)
	Light blue permanent	5G / SA connection (SA = Stand Alone)

<b>WLAN</b>	off	WLAN option switched off
	flashing red	MC searches for suitable APs or is in the process of authenticating itself
	green	WLAN connection OK. A brief orange (green + red) light indicates activity (sending or receiving) on the interface.
<b>LAN</b>	off	No device connected to the LAN ports
	green	A device is connected to one of the LAN ports and switched on.
	Flashing green / orange	Short orange flash when there is activity on the interface.
<b>Serial TCP mode</b>	off	The interface is inactive
	green	A communication partner has connected to the interface. When data is sent or received, the red LED is switched on for a short time.
	Flashing green / orange	
	Flashing green	The interface is active in <b>TCP</b> server mode and is waiting for a connection.
	flashing red	The interface is active in <b>TCP</b> client mode and is in the process of establishing a connection to the server.
<b>Serial UDP mode</b>	off	The interface is inactive
	green	Interface initialized
	Flashing green / white	Data is sent or received. If data is continuously being sent or received, the LED lights up white continuously.

Table 3: LED status display

## 1.5 Connections on the MC2X8

### 1.5.1 MC2X8 with M12 connection

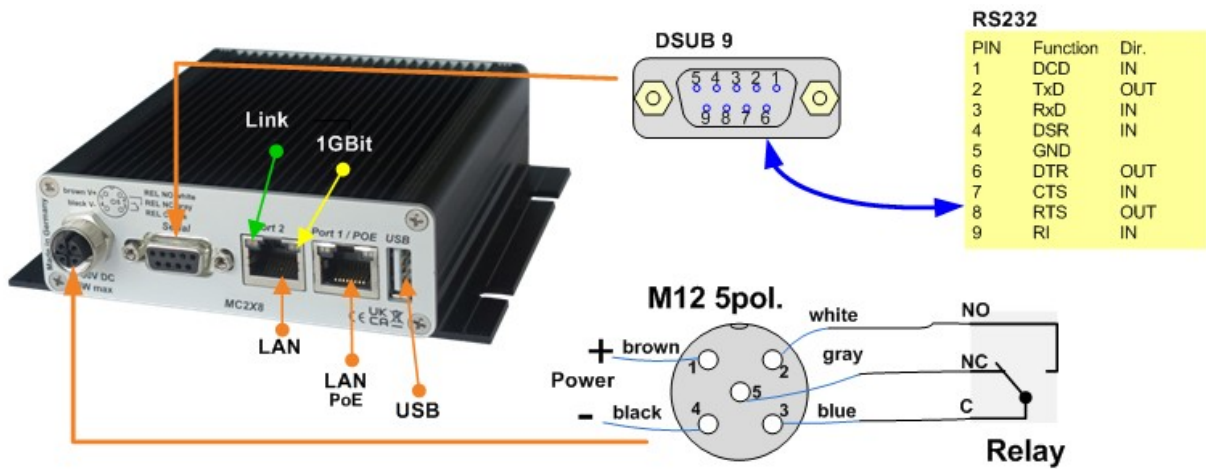
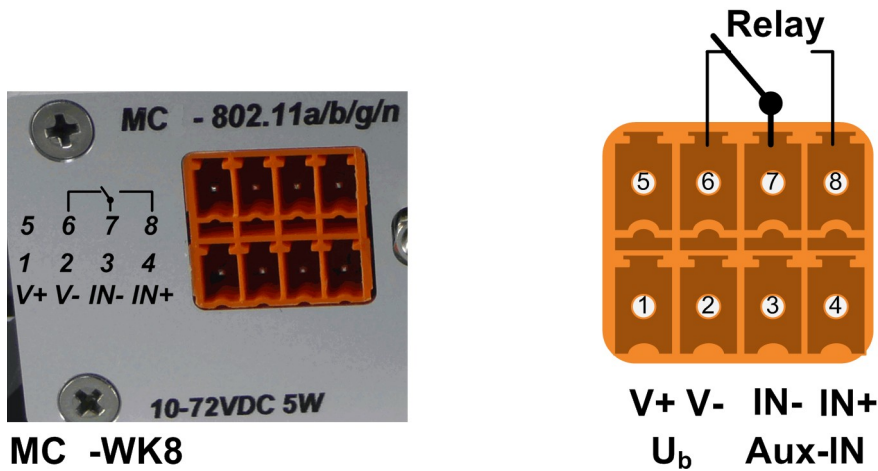

Figure 5: Connections on the rear of the MC2X8-M12

The illustration shows the MC2 in the standard version with a serial interface and a 5-pin M12 connector for the power supply and the built-in relay

The voltage connection for the MC2X8 is available in other variants:

### 1.5.2 MC2X8 with WK8 connection



## 1.6 Technical properties

Specifications:	
Ethernet	2 x LAN port 10/100/1000 MBit/s Auto MDI/MDIX
Serial	1 x RS232, 300-460.8 kbit/s, RTS, CTS, DSR, DTR, RI, DCD
USB	1 x USB 2.0 for connecting printers or USB adapters with various other interfaces
Relay	1 x changeover switch max 1A@24V, max 125VAC (M12 , WK8)
Switching input	1 x galvanically isolated 10 - 60V (WK8)
Antenna connection	2 x RPSMA
Power supply	12 - 60 VDC or 802.3af PoE via LAN port 1
Energy requirement	MC2X8-A (Wifi6) <= 10W (6W typical)      MC2X8-E (Wifi6 + 5G/LTE) <= 15W
Temperature range	0-60°
Dimensions	105x125x35mm
Weight	approx. 500g

## 1.7 WLAN interface

WLAN interface:	
Technology	802.11 ax WLAN (2.4 + 5 + 6 GHz band) IEEE 802.11 standards: a/b/g/n/ac/ax Features: OFDMA, 1024QAM, MU-MIMO, TPC/DFS, TWT Frequency: 2.4 GHz, 5 GHz, 6 GHz
Antennas:	2 antennas (2T2R MIMO)
Encryption	WEP (64,128bit) + TKIP, 128bit AES-CCMP, 256-bit AES-CCMP
Security	802.11i WPA(2)(3) - PSK WPA, WPA2 Personal and Enterprise, WPA3 802.1X EAP-TLS, EAP-TTLS/MSCHAPv2, PEAPv0 -MSCHAPv2
Frequency bands	2.4GHz ETSI 1-13, USA/Canada 1-11 5.0GHz ETSI + USA/Canada 24 (36 - 165) (U-NII-1 + UNII-2A + U-NII-2C+U-NII-3) 6.0GHz 5.945 - 6.425 MHz (EU)

Table 4 Properties of the WLAN interface

## 1.8 LTE-5G interface

### 1.8.1 MC2X8-E

A 5G module RM520N-GL from Quectel is installed in the MC2X8-E. This module has these features:

5G interface:				
Technologies / Bands	<table border="1"> <tr> <td>5G NR</td> <td>NSA</td> <td>n1/n2/n3/n5/n7/n8/n12/n13/n14/n20/n25/n26/n28/n29/n30/n38/n40/n41/n48/n66/n71/n75/n76/n77/n78/n79</td> </tr> </table>	5G NR	NSA	n1/n2/n3/n5/n7/n8/n12/n13/n14/n20/n25/n26/n28/n29/n30/n38/n40/n41/n48/n66/n71/n75/n76/n77/n78/n79
5G NR	NSA	n1/n2/n3/n5/n7/n8/n12/n13/n14/n20/n25/n26/n28/n29/n30/n38/n40/n41/n48/n66/n71/n75/n76/n77/n78/n79		

	SA	n1/n2/n3/n5/n7/n8/n12/n13/n14/n20/n25/n26/n28/n29/n30/n38/n40/n41/n48/n66/n71/n75/n76/n77/n78/n79										
LTE	LTE-FDD	B1/B2/B3/B4/B5/B7/B8/B12/B13/B14/B17/B18/B19/B20/B25/B26/B28/B29/B30/B32/B66/B71										
	LTE-TDD	B34/B38/B39/B40/B41/B42/B43/B48										
	LAA	B46 (only support 2 × 2 MIMO)										
UMTS	WCDMA	B1/B2/B4/B5/B8/B19										
GNSS	GPS/GLONASS/BeiDou (Compass)/Galileo											
Antennas:	Up to 4 Antenna											
GNSS	GPS, GLONASS, BeiDou, Galileo											
Data rates (max.)	<table border="1"> <thead> <tr> <th>Fashion</th> <th>Data rate</th> </tr> </thead> <tbody> <tr> <td>5G SA Sub-6</td> <td>DL 2.4 Gbps; UL 900 Mbps</td> </tr> <tr> <td>5G NSA Sub-6</td> <td>DL 3.3 Gbps; UL 600 Mbps</td> </tr> <tr> <td>LTE</td> <td>DL 1.6 Gbps; UL 200 Mbps</td> </tr> <tr> <td>WCDMA</td> <td>DL 42 Mbps; UL 5.76 Mbps</td> </tr> </tbody> </table>		Fashion	Data rate	5G SA Sub-6	DL 2.4 Gbps; UL 900 Mbps	5G NSA Sub-6	DL 3.3 Gbps; UL 600 Mbps	LTE	DL 1.6 Gbps; UL 200 Mbps	WCDMA	DL 42 Mbps; UL 5.76 Mbps
Fashion	Data rate											
5G SA Sub-6	DL 2.4 Gbps; UL 900 Mbps											
5G NSA Sub-6	DL 3.3 Gbps; UL 600 Mbps											
LTE	DL 1.6 Gbps; UL 200 Mbps											
WCDMA	DL 42 Mbps; UL 5.76 Mbps											

### 1.8.2 MC2X8-R

A 5G module RG255C-GL from Quectel is installed in the MC2X8-R. This module has these features:

<b>5G-Interface:</b>								
<i>Technologies / Bands</i>								
5G	NR SA	3GPP Release 17 RedCap SA operation, Sub-6 GHz n1/ 2/ 3/ 5/ 7/ 8/ 12/ 13/ 14/ 18/ 20/ 25/ 26/ 28/ 30/ 38/ 40/ 41/ 48/ 66/ 70/ 71/ 77/ 78/ 79						
	DL 2 x 2 MIMO	n1/ 2/ 3/ 5/ 7/ 8/ 12/ 13/ 14/ 18/ 20/ 25/ 26/ 28/ 30/ 38/ 40/ 41/ 48/ 66/ 70/ 71/ 77/ 78/ 79						
LTE	LTE-FDD	B1/ 2/ 3/ 4/ 5/ 7/ 8/ 12/ 13/ 14/ 17/ 18/ 19/ 20/ 25/ 26/ 28/ 30/ 66/ 70/ 71						
	LTE-TDD	B34/ 38/ 39/ 40/ 41/ 42/ 43/ 48						
	DL 2 × 2 MIMO	B1/ 2/ 3/ 4/ 5/ 7/ 8/ 12/ 13/ 14/ 17/ 18/ 19/ 20/ 25/ 26/ 28/ 30/ 34/ 38/ 39/ 40/ 41/ 42/ 43/ 48/ 66/ 70/ 71						
GNSS	GPS/ GLONASS/ BDS/ Galileo/ NavIC							
Antennas:	2 Antenna							
GNSS	GPS, GLONASS, BeiDou, Galileo							
Data rates (max.)	<table border="1"> <thead> <tr> <th>Mode</th> <th>Data rate</th> </tr> </thead> <tbody> <tr> <td>5G SA Sub-6</td> <td>223 Mbps (DL)/ 123 Mbps (UL)</td> </tr> <tr> <td>LTE</td> <td>195 Mbps (DL)/ 105 Mbps (UL)</td> </tr> </tbody> </table>		Mode	Data rate	5G SA Sub-6	223 Mbps (DL)/ 123 Mbps (UL)	LTE	195 Mbps (DL)/ 105 Mbps (UL)
Mode	Data rate							
5G SA Sub-6	223 Mbps (DL)/ 123 Mbps (UL)							
LTE	195 Mbps (DL)/ 105 Mbps (UL)							

## 1.9 Safety and installation instructions

### **CAUTION: Susceptibility of medical devices to interference**

This device emits radio frequency energy in the ISM frequency range (Industrial, Scientific, Medical).

- Ensure that all medical devices in the vicinity of this device meet the interference susceptibility requirements for this type of radio frequency energy.

### **CAUTION: Radio interference in residential areas**

This device is a class A device. This device may cause radio interference in residential areas.

- In this case, the operator may be required to take appropriate measures.

### **CAUTION: Electrostatic discharge**

This device contains components that can be damaged by electrostatic discharge (ESD).

- Take appropriate protective measures against electrostatic discharge.

### **ATTENTION: Power supply requirements**

The module is designed exclusively for operation with safety extra-low voltage (SELV) in accordance with EN/IEC 60950-1 and VDE 0805.

- Ensure the correct power supply.

### **ATTENTION: Requirements for the power source**

This device may only be operated with power supplies that meet the requirements of EN/IEC 60951-1 for power sources of limited power.

- Operate this device with a power supply that meets the requirements of EN/IEC 60951-1.
- Alternatively, operate this device in an enclosure that meets the requirements of a fire protection enclosure in accordance with EN/IEC 60951-1.

### **CAUTION: HF radiation**

This device emits radio frequency energy in the ISM frequency range (Industrial, Scientific, Medical).

- Operate the device with a minimum distance of 20 cm between the radiator or antenna and your body.

## 2 Initial start-up

For initial start-up, please first connect a computer with an Ethernet connection to the LAN connection of the MC using a patch cable.

After switching on the supply voltage to the MC, all LEDs will light up white briefly. Then only the ON LED lights up green, which soon starts to flash orange-green. After approx. 15-20 seconds, the application is fully operational and the LEDs light up with the function described above.

### 2.1 Initial start-up of the MC2X8

#### 2.1.1 Initial start-up with the MC-Config-Program

For its initial startup the MC is only able to communicate via its LAN-Port because typically there is no wireless network with a suitable SSID.

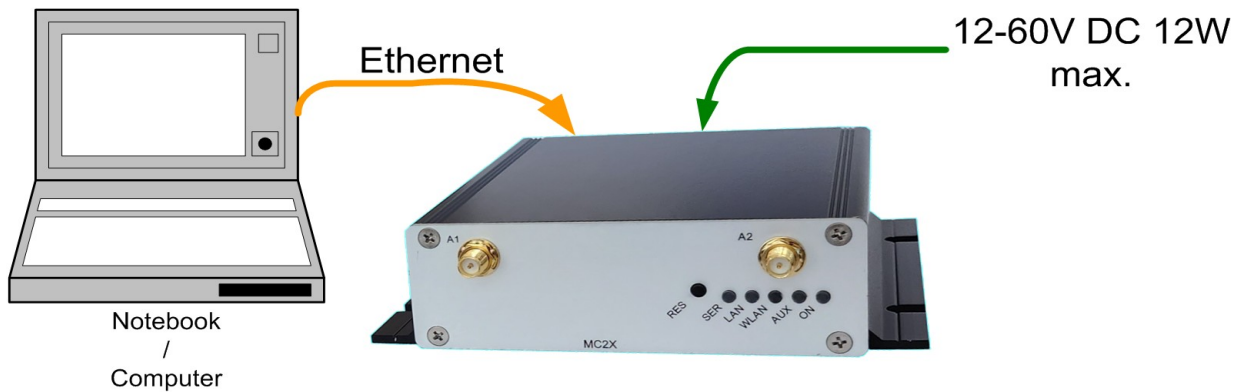

Figure 6: Setting for the initial configure of the MC MCX8

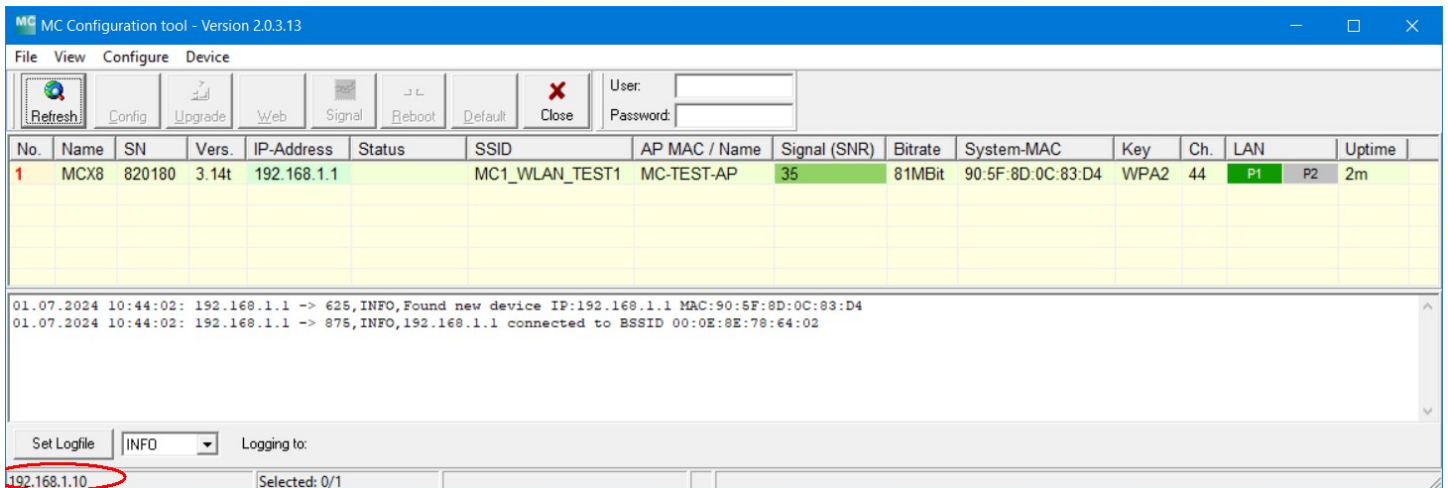

Figure 7: Initial setup with the MCConfig program

To do the „first time setup“ the MC has to be connected via the LAN-Interface to the computer (PC) that runs the MC-Config-Program.

What to take into account:

- The connected PC (Notebook) should have a fixed IP-Address on its LAN-Port (no DHCP).
- This IP should show up in the status field at the bottom right of the MC-Config program.
- If several IP addresses are listed there, you can specifically activate only the relevant interface with "Configure" → "Interfaces".

- After changing this setup, press the "Refresh" button on the MC-Config program again.
- An active Firewall on the PC might prevent communication with the MC.

After starting, the MC-Config program first determines all network interfaces that are currently active on the computer. Broadcast UDP requests are sent to these interfaces, to which MC devices respond. The responding devices are registered and displayed in a list.

In addition to device data such as name, serial number, firmware version, IP address and MAC address, WLAN connection data is also displayed. Initially, only the set SSID can be seen. If there is a connection to an access point, the MAC address and, for certain WLAN systems, the name of this AP is also displayed. The signal strength is displayed as an SNR value in dBm with a corresponding background color. The SNR values can be interpreted as follows:

- Signal  $\geq 40$   very good connection
- Signal  $\geq 30$   good connection
- Signal  $\geq 20$   Connection still sufficient
- Signal  $< 20$   Connection limited, the bit rates are reduced in order to transmit data.

**A more detailed description of how to use the MC-Config program can be found in a separate manual.**

### 2.1.2 Initial start-up via the MC WEB interface

If the MC-Config program is not to be used, the MC devices can also be commissioned via a web browser. To do this, you must set the LAN interface of the startup computer to a fixed IP address.

For example, the IP 192.168.1.10 with the subnet mask 255.255.255.0 would be suitable

If the MC2X8 starts with the default setting, you can access the MC homepage with the web browser by entering the address 192.168.1.1.

### 2.1.3 Startup via the MC WEB-Interface

If you do not want to or cannot use the MC-Config program, the MCX8 devices can also be put into operation using a WEB browser. To do this, you must set the LAN interface of the startup computer to a fixed IP address.

The IP 192.168.1.10 with the subnet mask 255.255.255.0 would be suitable, for example.

If the MC2X8 starts with the default setting you can access the home page of the MCX8 by using the WEB browser and entering the IP address 192.168.1.1.

## 2.2 Resetting the settings to default values

The reset button on the MC2X8 can be used to trigger the following functions:

- 1) Unmounting a USB memory stick plugged into the USB port. This allows memory sticks to be removed from the MC2X8 without data loss.
- 2) Restart the device
- 3) Reset the configuration to the "Factory Default" state and restart the firmware.

The respective function is carried out depending on how long the button is pressed.

To unmount, the reset button is held down for 1 - 3 seconds. During this time, all LEDs except for "Power" flash alternately red blue green. If the button is released during this phase, only the unmounting is carried out. The program then continues to run normally.

After holding down the reset button for approx. 5 seconds, the flashing stops. If the reset button is then released, the MC2X8 performs both an unmount of the USB memory and a restart.

After 10 seconds, all LEDs turn white and a color change of all LEDs (except power) from blue - red - green - violet etc. begins. If the reset button is held down until the MC2X8 is restarted, the configuration is reset to the factory default settings.

## 2.3 Default-Konfiguration

The MC2X8 can be reset to the factory default settings in 3 ways:

- 1) Via the reset button → 2.2
- 2) With the MC-Config program → 
- 3) Via the website → "Device" → "Configuration management" → "Reset configuration to defaults"  
This opens the configuration menu with the default settings.  
If necessary, you can make your own settings here and set and activate them with "Save & Apply".

The MC2X8 has the following (important) factory settings:

Device Name: „MC2X8“  
**Global Security: Best**  
Enable WLAN = off

Enable LTE = off

BridgeMode = NAT

### LAN-Port

LAN-IP = 192.168.1.1  
LAN Netmask= 255.255.255.0  
LAN Gateway = 0.0.0.0  
DHCP-Server = off

WLAN IP = 192.168.170.100  
WLAN Netmask = 255.255.255.0  
WLAN Gateway = 192.168.170.1

user = “ (empty)  
password = “ (empty)  
Seriell 1: inactive  
Relais: inactive  
Input: inactive

## 2.4 Quick guide to configure the MCX8

### 2.4.1 Establish a WLAN connection:

All parameters not listed here, should be left at there default values.

Menu	Submenu	Parameters	Value	Comment
Wireless	Main parameter	Enable wireless interface	ON	
		Wireless Mode	Infrastructure	MCX8 as WLAN client in the access point infrastructure
		Phy Mode	2.4GHz+5GHz+6GHz	If you are sure which band the right access point works in, you should narrow down the selection here.

	SSID - Encryption Profile → PR1	Enable profile	ON	
		SSID	YourSSID	Network name as it is set in the AP
		Encryption mode	WPA/WPA2/WPA3 (Auto)	The MCX8 takes the correct value from the AP
		Keying Protocol	Car	Here too, the MCX8 adjusts itself to the AP
		Key	PSC of the AP	PSK as set in the AP.

Network	Bridge Mode	These settings affect the mode of the WLAN / LTE bridge. With an active LTE interface, only (single) NAT mode is possible. Other modes can be used without LTE.		
		Bridge Mode	NAT	The MCX8 therefore has its own network with a specific IP address on the LAN side
		Local IP Address	aaa.bbb.ccc.ddd	IP address via which the MCX8 is addressed on the LAN side. LAN clients must configure this address as the gateway IP.
		Subnet mask	255.255.255.0	
		Enable DHCP server	OFF	This can be used to activate a DHCP server operated by the MCX8, which assigns IP addresses from a predefined range in response to requests.

Network	IP			
		Enable WLAN DHCP Client	???	If the IP on the WLAN interface is to be obtained from a DHCP server, then set to "ON".
		Hostname	MCX8 Name	A device name with which the MCX8 identifies itself to the DHCP server can be specified here. If this Parameter is empty, the given device name (Admin → Device name) is taken.
		IP	Static IP	If a static IP is specified, the data is entered here.
			Subnetmask	
			Gateway IP	
			DNA 1,2	

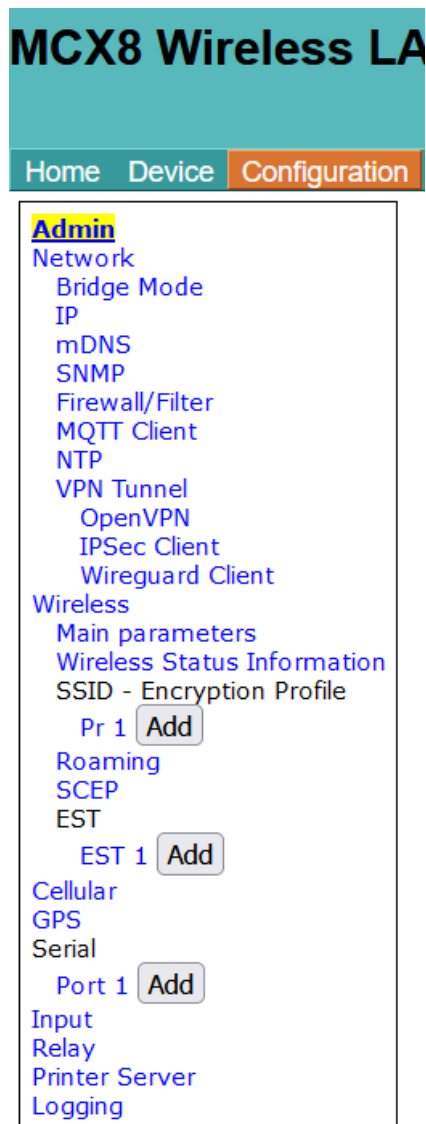

## 2.5 Configuring the MC2X8

Almost all parameters that can be set under “Configuration” are also available for the MC1,2,4,6 devices. Explanations can be found in the manual for these devices.

-> <https://www.modas.com/en/downloads/mc1-mc2-mc4-mc6/#Manual>

This also applies to the description of the Rest API, which is also described in the manual for the MC1,2,4,6 devices.

## 3 5G / LTE settings

The various configuration options available for 5G / LTE are explained below:

### Cellular

Enable LTE	Activate this checkbox to enable the LTE function so that the device can connect to the LTE network.
PIN	Enter the personal identification number (PIN) of your SIM card to access the network.
Username + Password	Enter the user name + password provided by your network operator to connect to the LTE network.
Select Auth	This information is not always required Select the authentication mode, e.g. PAP or CHAP, as required by your network operator.

APN	Enter the access point name (APN) that is used to connect to the LTE network. This information is provided by your network operator.
Roaming	Activate this checkbox to enable mobile data roaming so that the device can connect to other networks when traveling.
Enable watchdog	Select this checkbox to enable a connection monitoring function that uses DNS queries to monitor the stability of the network connection.
Watchdog Host Lookup	Specify a host name for the watchdog to test the connection with a lookup.
Connection timeout	Set the timeout of the watchdog in seconds, which determines how long the watchdog waits before it considers the connection to be interrupted.
Custom LTE band	With this setting, you can restrict the device to certain LTE bands, e.g. B43 for LTE-B43 only. If you want to use multiple bands, separate them with commas, e.g. B20,B43 for both bands. ( experimental function )
Scan for providers	Activate this option so that the device can search for available network operators. ( experimental function )
Select provider	Enter the provider ID you wish to connect to or leave the field empty to activate automatic provider selection. ( experimental function )
<b>State information</b>	
Query Signal Status	Set the interval (in seconds) for querying signal strength indicators such as RSSI (Received Signal Strength Indicator), RSRQ (Reference Signal Received Quality) and RSRP (Reference Signal Received Power).
<b>Debugging</b>	
Debug LTE	This option allows you to select the protocol configuration for LTE. By selecting the appropriate protocol configuration, you can monitor the performance and status of the LTE connection, making it easier to identify and resolve potential problems in real time.
<b>Traffic Dump Configuration</b>	
	This option can be used to record data traffic via the LTE interface. This may generate large amounts of data that are stored in the internal flash. A filter can be used to limit the amount of data if required.
<b>Routing</b>	
	This determines which interface is prioritized for use when data needs to be sent.

### 3.1 Unlocking the SIM card by entering the PUK

If an incorrect PIN has been configured for the inserted SIM card, the SIM card is blocked after a certain number of failed attempts. The LTE module signals this to the operating system and requests the PUK associated with the SIM card

The input field at the start of the form is then activated to enter this PUK.

Home Device Configuration Statistics Support

Enter PUK SIMA  Send PUK (Disabled - not required)

## 4 Open Source Compliance Information

Version: MC WLAN Client Adapter

To whom it may concern,

Written Offer

This product contains software whose rightholders license it under the terms of the GNU General Public License, version 2 (GPLv2), version 3 (GPLv3) and/or other open source software licenses. If you want to receive the complete corresponding source code we will provide you and any third party with the source code of the software licensed under an open source software license if you send us a written request by mail or email to the following addresses:

Email: modas oss support team: [opensource@modas.de](mailto:opensource@modas.de)

Postal:

modas mobile Datensysteme GmbH  
Belziger Str, 69-71  
10823 Berlin/Germany

detailing the name of the product and the firmware version for which you want the source code and indicating how we can contact you.

PLEASE NOTE THAT WE WILL ASK YOU TO PAY US FOR THE COSTS OF A DATA CARRIER AND THE POSTAL CHARGES TO SEND THE DATA CARRIER TO YOU. THE AMOUNT CAN BE VARIED ACCORDING TO YOUR LOCATION AND MODAS OSS SUPPORT TEAM WILL NOTIFY THE EXACT COST WHEN RECEIVING THE REQUEST. THIS OFFER IS VALID FOR THREE YEARS FROM THE MOMENT WE DISTRIBUTED THE PRODUCT AND VALID FOR AS LONG AS WE OFFER SPARE PARTS OR CUSTOMER SUPPORT FOR THAT PRODUCT MODEL.

FOR MORE INFORMATION SEE ALSO:

<http://download.modas.com/Source>